

Combination Station Vertical

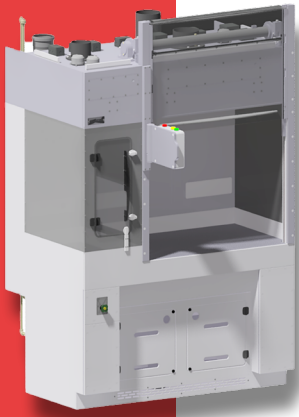

Configuration

Automatic vertical front sash (clear)

Light curtain for activity monitoring

Integrated LED lights

Monitoring of differential pressure and filter loading

Evaporation chamber with integrated pass-through and front door with position sensor

Temperature monitoring of exhaust air

Programmable logic controller (PLC) for monitoring and controlling of operation, airflows, and equipment

Supply air filters as needed

Volume flow controllers for supply and exhaust air

Optional configuration

Connections for hotplates

Bottling station (various versions)

Exhaust tub flushing

Drain / wastewater connection

Customized media supply (interior and exterior)

Remote monitoring and servicing

Integrated ultrapure water system (various manufacturers)

Integrated acid stills

Sink or ultrasonic basin

Base cabinet (vented) with hinged doors or drawers

Exhaust air scrubber and exhaust air irrigation

Technical data

Materials	PP, PET, POM, PFA, PVDF
Operating voltage	400V/50Hz 16A or 208V/60Hz 20A
Air requirements	Working chamber: supply air min. 300 m ³ /h, exhaust air min. 375 m ³ /h Evaporation chamber: supply and exhaust air min. 150 m ³ /h (total width: 1200 mm)
Air velocity in working area	approx. 0.15 m/s in normal operation
Terminal supply air filters	High-performance HEPA/ULPA filter, class H13 to U16 (depending on requirements)
Cleanroom class according DIN EN ISO 14644-1	Class 3 or better „at rest“
Illuminance	> 750 Lux in both chambers
Interfaces	Ethernet or other common fieldbus systems and serial interfaces
Dimensions	1200 x 975 x 2260 mm (W x D x H), Widths 900 mm, 1500 mm and 1800 mm also available
Weight (without equipment)	260 kg for 1200 mm width (320 kg, 380 kg for wider models)
Dimensions working area	770 x 690 x 880 mm (W x D x H), width varies with total width
Dimensions evaporation chamber	400 x 690 x 880 mm (W x D x H)
Working height	700 mm, 900 mm



Combination Station vertical

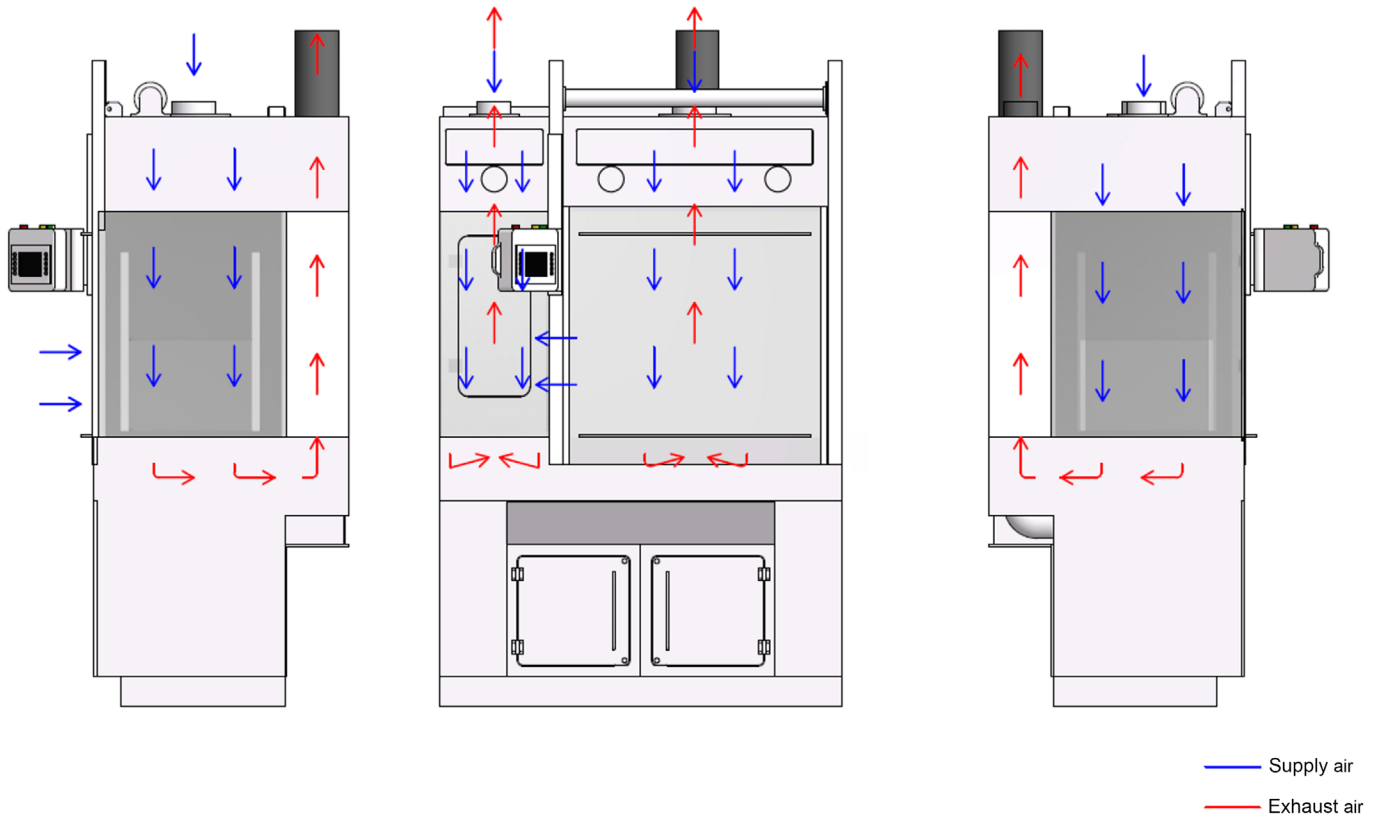

Product features

- Metal-free construction (no exposed metal) to prevent contamination and corrosion
- Supply air provided directly from ventilation system (via dedicated duct) or, alternatively, pulled from room (using support fan)
- Vertical laminar flow achieved through a fine-meshed monofilament fabric diffuser
- Laminar airflow throughout the entire working chamber; air is exhausted through perforated work surface
- Control of supply air and exhaust air via the PLC ensures the correct pressure in the working chamber
- Compliant with DIN EN 14175-3 safety and performance standards (containment, air exchange efficiency)
- Simultaneous protection of personnel and samples/products
- Outstanding air and energy efficiency due to optimized and smart airflow management
- Exhaust air can be discharged via air scrubbers or directly transferred to the exhaust air system
- Room air can also be extracted via the base module and fed into the ventilation system ('recirculating air')
- Separate chamber (with independent vertical laminar flow) for isolated evaporation / hotplate usage

Contact & Support

MK Versuchsanlagen GmbH & Co. KG
Stueckweg 10 - D-35325 Muecke-Merlau
Tel.: +49 (0) 6400-9576030
sales@mk-versuchsanlagen.de
www.mk-versuchsanlage.de

